

2

SML GOVERNMENT DEGREE COLLEGE

YEMMIGANUR, KURNOOL DIST.

CERTIFICATE COURSE

ON

ARDUINO PROGRAMMING AND INTERFACING

ORGANISED BY

THE DEPARTMENT OF PHYSICS, 2019-2020.

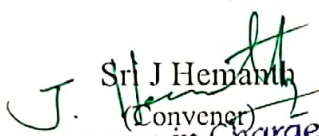
 Sri J Hemamba
 (Convener)
 Lecturer in Charge
 Dept. of Physics
 S.M.L Govt. Degree College
 YEMMIGANUR 518 360
 Kurnool Dt. A.P.

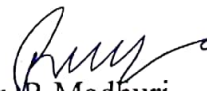
 Dr. R Madhuri
 (Co- Convener)

 B Masood vali
 (Coordinator)

 Dr. V. V. S. KUMAR
 PRINCIPAL
 S.M.L Govt. Degree College
 YEMMIGANUR, Kurnool (D)



INDEX

S.No.	Name of the Topic/Activity	Page. No.
1.	Brief report	3
2.	Permission letter	4
3.	Student willingness	5
4.	Course overview	7
5.	List of topics	8
6.	Basic Electrical components	10
7.	Resistor colour code calculation	14
8.	Multimeter	14
9.	Switches, Potentiometers, Sensors and actuators	19
10.	Diode and Light emitting diode	21
11.	Introduction to IOT	23
12.	Block diagram of Arduino UNO	24
13.	Pin diagram of Arduino UNO	24
14.	Variables and data types	25
15.	Conditional statements	26
16.	I/O functions	27
17.	Arduino projects	29
18.	Question paper	39
19.	Award list	48
20.	Certificate distribution	50

Certificate Course- Arduino Programming and Interfacing

Brief report:

The Department of Physics, SML Govt. Degree College organized a certificate course in Arduino Programming and Interfacing for B.Sc students during the academic year 2019-20 for a period of 45 days ie.17-12-2019 to 22-02-2020.

In this connection, a meeting was held by the In-Charge and faculty members of Physics department along with Dr.V.V.S Kumar, principal of the college. The head of the Institution presided over the inaugural function and appreciated the faculty of the department for organizing such a valuable certificate course. He advised the students to grab the opportunity by joining the course.

During the course period the following faculty members of the college visited the classes & laboratory work and presented their valuable suggestions for the betterment of the program. The faculty members involved in the program are

1. Dr. K. Nagarajasetty, Lecturer in chemistry, SML GDC
2. Dr. M. Suseelamma, Lecturer in Botany, SML GDC
3. Smt. S. Fakrunnisa Begum, Lecturer in Zoology, SML GDC

After the completion of course, an assessment test including theory and practical is conducted to evaluate the performance of the participants.

On February 23th – 2020, a valedictory function was organized by the Department of Physics and Dr. K. Mahaboob Basha, principal of the college addressed the meeting and said that it was a remarkable achievement of the department of Physics and congratulated all the participants. Finally, the principal distributed the certificates. All the teaching and non-teaching staff attended the program and made it a grand success.

We hereby enlighten my utmost gratitude to Dr. V. V. S Kumar, principal SJGC (A), Kurnool, Dr. K. Mahaboob Basha, Principal, SMLGDC, Yemmiganur, teaching and non-teaching staff who involved directly or indirectly and my best wishes to all the participants

Date: 16-12-2019

To
The Principal
S.M.L Govt. Degree College
Yemmiganur

Respected Sir,

Sub: Department of Physics – to start a certificate course in "Arduino Programming and Interfacing" permission request – regarding

Kg
16/12/2019

X

I am very glad to inform you that, Department of Physics has drafted a certificate course in "Arduino Programming and Interfacing" for B.Sc (M.P.C & M.P.Es) students of our college. The faculty members of the department are enthusiastic to conduct the course in this semester of 2019-20 academic year out of college working hours.

In this connection, I request you to kindly accord us permission to start the course for the benefit of the students as well as other stake holders.

Thanking you

Yours faithfully,

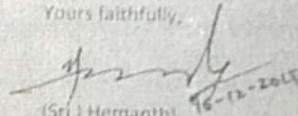

(Sri J. Hemanth)
I/C of the Department of Physics
SML GDC Yemmiganur

SML Government Degree College, Yemmiganur

Department of Physics

Willingness of Students for the certificate course "Arduino Programming and Interfacing"

S. No	Regd. No. of student	Name of the student	Group and Class	Cell No.	Signature
1.	18360049001	B RAMAKRISHNA	B.Sc(M.P.Cs)- II Year	9848563828	B. Ramakrishna
2.	18360049002	B BHEEMA SEKHAR	B.Sc(M.P.Cs)- II Year	8297368607	Bheema
3.	18360049004	C NAKASIMHULU	B.Sc(M.P.Cs)- II Year	9398824226	Narasimhulu
4.	18360049006	G SHIVA RAJU	B.Sc(M.P.Cs)- II Year	8008422586	Shiva
5.	18360049010	K SOMI REDDY	B.Sc(M.P.Cs)- II Year	9553713580	K. Somireddy
6.	18360049012	M NARASAPPA	B.Sc(M.P.Cs)- II Year	9030202584	M. Narasappa
7.	18360049016	S DASTAGIRI	B.Sc(M.P.Cs)- II Year	6305605454	S. Dastagiri
8.	18360049017	S PRASANNA KUMAR	B.Sc(M.P.Cs)- II Year	6281090906	S. Prasanna Kumar
9.	18360049018	SHAIK SHA VALI	B.Sc(M.P.Cs)- II Year	8008422586	S. Shaik Sha Vali
10.	18360049019	T BASAVARAJU	B.Sc(M.P.Cs)- II Year	9000408101	T. Basavaraju
11.	18360049020	T VEERASHEKAR	B.Sc(M.P.Cs)- II Year	6302295283	T. Veerashakar
12.	18360049021	V DUSHYANTHUDU	B.Sc(M.P.Cs)- II Year	8790621257	V. Dushyantudu
13.	19360049004	B THIRUMALESH	B.Sc(M.P.Cs) - I Year	6305223898	B. Thirumalesh
14.	19360049005	C RAMESH	B.Sc(M.P.Cs) - I Year	9676620125	C. Ramesh
15.	19360049007	C MAHADEVI	B.Sc(M.P.Cs) - I Year	7396951426	C. Mahadevi
16.	19360049008	D NAGASRAVANI	B.Sc(M.P.Cs) - I Year	9885328528	D. Nagasravani
17.	19360049010	D MABASHA	B.Sc(M.P.Cs) - I Year	9030202584	D. Mabasha
18.	19360049012	G SANDHYA RANI	B.Sc(M.P.Cs) - I Year	7396951426	G. Sandhya Rani
19.	19360049013	K SANA	B.Sc(M.P.Cs) - I Year	9381093638	K. Sana
20.	19360049021	S SREERAMULU	B.Sc(M.P.Cs) - I Year	9381329590	S. Sreeramulu
21.	19360049023	U LAKSHMINARAYANA	B.Sc(M.P.Cs) - I Year	9441475330	U. Lakshminarayana
22.	19360049014	M RAJESWARI	B.Sc(M.P.Cs) - I Year	8317679760	M. Rajeswari

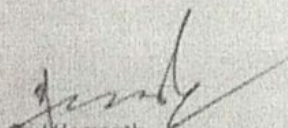

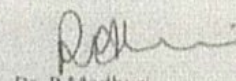
Sri J. Hemanth
(Convener)

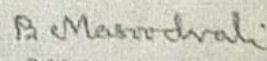

Dr. R. Madhuri
(Co. Convener)

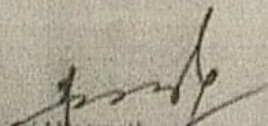
B. Masood Valli
(Coordinator)

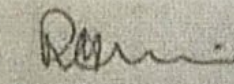
S. No	Regd. No. of student	Name of the student	Group and Class	Cell No.	Signature
23	173049036	B NARASAMMA	B.Sc(M.P.Cs)- III Year	-----	B NARASAMMA
24	173049038	B VISHNU SWETHA	B.Sc(M.P.Cs)- III Year	-----	Swetha
25	173049039	BANDARU VIJAYA KUMAR	B.Sc(M.P.Cs)- III Year	9642264377	Vijay
26	173049040	C SEKHAR	B.Sc(M.P.Cs)- III Year	8688699663	Sekhar
27	173049041	PALLE KASIM	B.Sc(M.P.Cs)- III Year	7095244035	Kasim
28	173049042	Y SURYANARAYANA GOUD	B.Sc(M.P.Cs)- III Year	8179959915	Surya
29	173049016	A SHANKAR	B.Sc(M.P.Cs)- III Year	9381173340	Shankar
30	173049017	BOYA CHINNA RANGANNA	B.Sc(M.P.Cs)- III Year	7729928136	Ranganna
31	173049018	BOYA HARI KRISHNA	B.Sc(M.P.Cs)- III Year	6303656332	Harikrishna
32	173049019	BOYA RANGANNA	B.Sc(M.P.Cs)- III Year	8096883654	Ranganna
33	173049020	B T R CHIRANJEEVI	B.Sc(M.P.Cs)- III Year	9704896898	Chiranjeevi
34	173049021	C SAIKRISHNA REDDY	B.Sc(M.P.Cs)- III Year	9182180030	Saikrishna
35	173049022	CHIKKEM VIJAY KUMAR	B.Sc(M.P.Cs)- III Year	9642264377	Vijay Kumar
36	173049023	GANDALAM AMRUTHA RAJU	B.Sc(M.P.Cs)- III Year	-----	G. Amrutha
37	173049025	GUJJALA DAMODHAR	B.Sc(M.P.Cs)- III Year	6301141504	Damodhar
38	173049026	K SURYA PRAKASH	B.Sc(M.P.Cs)- III Year	9490074560	Surya Prakash
39	173049027	KADIVELLA GOUSE MODIN	B.Sc(M.P.Cs)- III Year	9640148840	Gousemodin
40	173049028	KANAKAVEEDU VEERESH	B.Sc(M.P.Cs)- III Year	9052862083	Veeresh
41	173049029	KANIRE VEERESH BABU	B.Sc(M.P.Cs)- III Year	-----	Veeresh Babu
42	173049030	KATHIF YOUNIS BASHA	B.Sc(M.P.Cs)- III Year	7330947660	Younis
43	173049031	MANGALI SHIREESHA	B.Sc(M.P.Cs)- III Year	-----	Shireesha
44	173049033	NANDAVARAM FARUDDIN	B.Sc(M.P.Cs)- III Year	9154116714	Faruuddin
45	173049034	SHIAK PISARI HASOOL	B.Sc(M.P.Cs)- III Year	9553838370	S. Rasmi

Sri J. Heranth
(Convener)

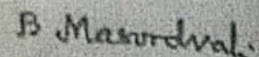
Dr. R. Madhuri
(Co-Convener)

B. Masoodvali
(Coordinator)

7

SML Government Degree College
Yemmiganur, Kurnool dist., Andhra Pradesh
Certificate course on
Arduino Programming and Interfacing, 2019-20

Course Code: PHY-C-1-2019-20	Course Title: Basics of Arduino Programming and Interfacing
-------------------------------------	--

Course Overview

The course 'Arduino programming and Interfacing' is designed to acquaint the Internet of things (IOT) to the young minds. The curriculum includes the basics of Electronics and Arduino programming which are the gateways to the IOT world. It will favour the learners, by inculcating the creative, innovative ideas of hardware interfacing and their administration using software programming. In the curriculum, emphasis is laid on enhancing learner's technical, problem solving skills and thus on their employability.

Module one commences with 'Basics concepts of electricity', and is aimed at imparting the students with an understanding of the concept and identification of basic electrical elements which they apply in the upcoming modules. These concepts are very much important to design an effective and accurate IOT system.

Module two focuses on hardware designing components such as bread board, switches, potentiometers, etc., that is essential for any IOT system. The students will be able to learn and understand the functionality and application of these electronic components.

In Module three, emphasis is laid on 'Types of Arduino boards and Arduino UNO'. This module acquaints the students with the architecture and pin diagram of Arduino UNO electronic board and equips them with the knowledge of on board components.

Module four deals with the 'programming skills' of Arduino. In this module students actively participate in learning the programming instructions that actually drive the hardware board. It empowers the students with effective communication techniques using a personal computer. It also aims to polish their writing skills.

Module five dwells on basic projects using Arduino UNO. This module is the practical implication of all the knowledge that the student has gained in first four modules. The module will help students to get a better understanding of Arduino interfacing with PC and programming. Thus after completion of the course, student will confidently step towards building the carrier in Internet of Things

Learning Outcomes

The course aims to build up student's analytical and programming skills to deal with the practical situations of IOT world. On successful completion of this course, students will be able to:

1. Exhibit an understanding of the basic principles of electronics
2. Effectively choose a right electrical component for a specific circuit
3. Develop an understanding of selecting and designing an effective Arduino based IOT system for a specific task.
4. Write clear, concise and correct sketch for an IOT hardware that exhibits their professional programming skills.
5. Understand and effectively use Arduino UNO for specific applications
6. Give effective demonstrations of IOT systems with optimum use of hardware and software tools

7. Think critically to enhance interfacing and programming abilities

List of Topics/ Modules

Topic/ Module	Contents/ Concepts	Session number
Module I: Introduction to basic electrical components and their identification.	<ul style="list-style-type: none"> • Voltage, electrical current • resistance and their units • Ohm's law • Resistors, their identification using color codes • Getting familiar with Multimeter • Measuring voltage, current and resistance using multimeter. 	2-10
Module II: Switches, Potentiometers,	<ul style="list-style-type: none"> • Bread board • Switches, potentiometer • Diodes • Light Emitting diodes 	11-18
Module III: Introduction to IOT and Arduino	<ul style="list-style-type: none"> • Internet of things • Introduction to Arduino • Types of Arduino boards • Arduino UNO • Pin diagram of Arduino UNO 	19-25
Module IV: Programming language of Arduino	<ul style="list-style-type: none"> • Variables and data types • Conditional statements • I / O functions 	26-35
Module V: Applications of Arduino UNO	<ul style="list-style-type: none"> • Project to blink LED • Analog read serial • Digital read serial • Read analog voltage • Controlling an LED using push button 	35-45

Evaluation Criteria

The students shall be evaluated on practical as well as theoretical topics covered in the course. It shall be both in written and practical form.

Recommended/Reference Text Books and Resources:

Text

Arduino sketches-Tools and techniques for programming by James A. Langbridge

References

- a) *Learn to program in Arduino C* by William P. Osborne
- b) *Arduino starter kit manual* by Mike Roberts.
- c) *Building Arduino projects for Internet of Things* by Adeel Javed.

Web Resources

- <https://www.arduino.cc/en/Tutorial/BuiltInExamples> an Arduino official site
- <https://www.tinkercad.com/dashboard?type=circuits&collection=designs> an interactive simulator to get familiar with the Arduino UNO

SML Government Degree College, Yemmiganur
 Certificate course on
Basics of Arduino Interfacing and programming, 2019-20
 Text material

Chapter 1: Basic Electrical components and their identification

Electric voltage:

Voltage is generally defined as the electric potential difference between two points that actually exists due to the variation in charge concentration. It is measured in units of volts (V). The voltage at a point is measured using either a voltmeter or a multimeter.

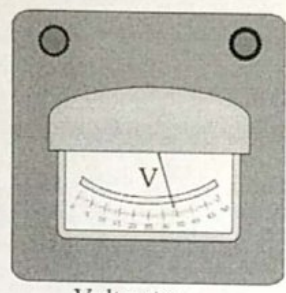

Voltmeter



voltmeter schematic symbol

Electric current:

The rate of flow of electric charge or electrons in a circuit is defined as Electric current. It is measured in units of Ampere(A). The instrument used to measure electric current is called an Ammeter.

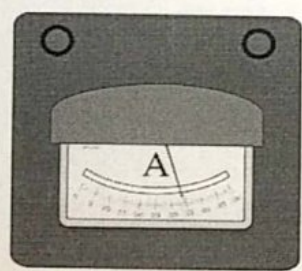

Ammeter

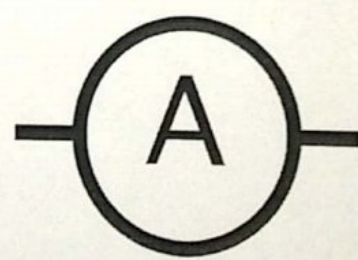

Ammeter schematic symbol

Electrical resistance:

The obstruction for the free flow of electrons in a material is defined as the resistance. Its units are Ohm. The value of resistance can be measured by using a multimeter or resistor color codes.



Resistor

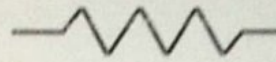

schematic symbol of a resistor

Ohm's law:

The Ohm's law says that amount of current (I) flowing through a conductor is proportional to the potential (voltage-V) difference at its ends.

$$\text{i.e. } V \propto I$$
$$V = IR$$

Where R is the resistance of the conductor

This law can be used to find one quantity when the other two are known.

Resistors:

A resistor is a device that offers a desired resistance for the current flow. Resistors are generally employed to limit the value of current flowing through a circuit. There are different types of resistors available in the market with diverse rating and sizes. Some of these are discussed below.

- Wire wound Resistors

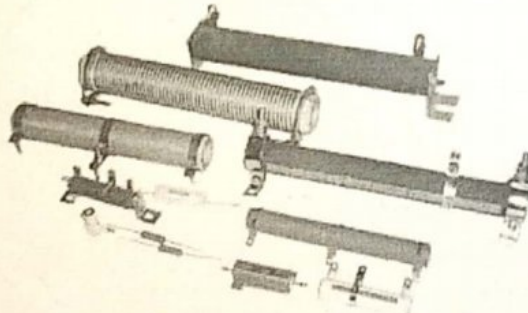

Wire wound Resistors

These resistors vary in physical appearance and size. These wire-wound resistors are commonly a length of wires usually made of an alloy such as nickel chromium or copper-nickel manganese alloy. These resistors are the oldest type of resistors having excellent properties like high power ratings and low resistive values.

- Metal film Resistor

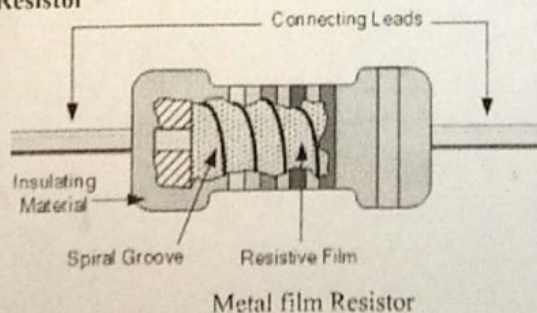

These resistors are made from metal oxide or small rods of ceramic-coated metal. Their resistivity is controlled by the thickness of the coating layer. The properties like reliability, accuracy and stability are considerably better for these resistors. These resistors can be obtained in a wide range of resistance values (from a few ohms to millions of ohms).

- **Thick film and Thin film Resistors**

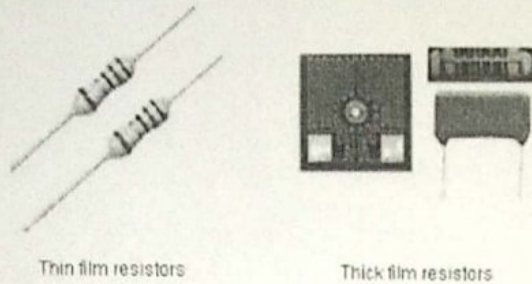

Thin film resistors are made by sputtering some resistive material on to an insulating substrate (a method of vacuum deposition), and are therefore more expensive than the thick film resistors. The resistive element for these resistors is approximately 1000 angstroms. Thin film resistors have better temperature coefficients, lower capacitance, low parasitic inductance and low noise. These are mostly used for applications that require high accuracy and high stability. These films have tolerances ranging from 1 to 2%, and a temperature coefficient between + 200 or +250 and -200 or -250. These are widely available as low-cost resistors.

- **Surface mount Resistors**



Surface mount Resistors

Surface mount resistors come in a variety of packages size and shape agreed by the EIA (Electronic Industry Alliance). These are made by depositing a film of resistive material and don't have enough space for color-code bands owing to small size. SMDs are smaller than their traditional counterparts. They are often square, rectangular or oval in shape, with very low profiles. Instead of wire leads that go through the PCB, SMD's have small leads or pins that are soldered to pads on the surface of the board. The tolerance may be as low as 0.02% and consists of 3 or 4 letters as an indication. The smallest size of the 0201 package is a tiny 0.60mm x 0.30mm resistor and this three number code works in a similar way to the color code bands on wire-ended resistors.

- **Network Resistors**

Network resistors are a combination of resistances that give identical value to all pins. These resistors are available in dual inline and single inline packages.

- **Variable Resistors**

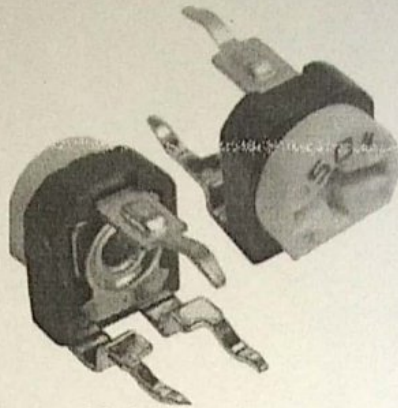

Variable Resistors

Most commonly used types of variable resistors are potentiometers and presets. These resistors consist of fixed value of resistance between two terminals and are mostly used for setting the sensitivity of sensors and voltage division. A wiper or a knob (moving part of the potentiometer) changes the resistance that can be rotated. These resistors have three tabs / pins, in which the wiper is the middle tab / pin that acts as a voltage divider, when all the tabs are used. When the middle tab is used along with the other tab, it becomes a rheostat or variable resistor. When only the side tabs are used, then it behaves as a fixed resistor.

- **Special Resistors**

These are classified into two types: 1) Thermistors and 2) Light-Dependent Resistors

Thermistors

A thermistor is a type of resistor whose resistance is dependent on temperature. Thermistors are of two opposite fundamental types:

- Negative temperature coefficient(NTC) thermistors are the devices whose, resistance decreases as temperature rises. An NTC is commonly used as a temperature sensor, or in series with a circuit as an inrush current limiter.
- Positive temperature coefficient(PTC) thermistors are the devices whose , resistance increases as temperature rises. PTC thermistors are commonly installed in series with a circuit, and used to protect against over current conditions, as resettable fuses.

- **Light-dependent Resistors (LDR)**



Light-dependent Resistors

Light-dependent resistors are very useful in different electronic circuits, especially in clocks, alarms and street lights. When the resistor is in darkness, its resistance is very high (1 Mega Ohm) while in light, the resistance falls down to a few kilo Ohms. These resistors come in different shapes and colors. Depending on the ambient light, these resistors are used to turn 'on' or turn 'off' devices.

Resistor Color Code Calculation

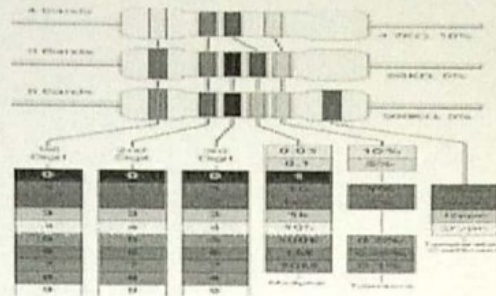

In a 4 band resistor:

- The first digit or band indicates, first significant figure of component.
- The second digit indicates, second significant figure of component.
- The third digit indicates the decimal multiplier.
- The fourth digit indicates tolerance of value in percentage.

5 Bands Resistor Color Code:

In the above 5 bands resistors, the first three colors indicate significant values, and the fourth and fifth colors indicate multiplying and tolerance values.

6 Bands Resistor Color Code:

In the above 6 bands resistors, the first three colors indicate significant values; the Fourth color indicates multiplying factor, the fifth color indicates tolerance and the sixth indicates TCR.

In the case of Surface mounted resistors their value can be find using EIA – 96 system available at the site <http://www.resistorguide.com/resistor-smd-code/> and by using the android application 'Resistor SMD code calculator'

Multimeter:

A multimeter is a device used to measure voltage, resistance, current, capacitance and continuity of a circuit.

The Dial Setting

The dial of the DMM allows you to choose the function you're interested in measuring. Whether you intend to measure one of the three elements of Ohm's Law, or a more advanced function like frequency or capacitance, you must first set the dial to the appropriate function.

Setting the Range

The dial also plays another essential role in measuring electricity – that of determining the range of measurement. The range you select on the dial determines the placement of the decimal point as it appears on the LCD. In turn, the position of the decimal point determines how refined, or precise, your reading is. This is called resolution.



Symbols	Measurement Functions	Descriptions
V~	AC Voltage	Measures amount of AC Electrical Pressure
V—	DC Voltage	Measures amount of DC Electrical Pressure
mV	Milli Volts	.00V or 1/1000V
A	Amperes	Measures amount of electron flow
mA	Milli Amperes	.001 or 1/1000A
Ω	Ohms	Measurement of resistance to the flow of electron
⎓	Diode	Device used to control direction of electron flow
)))	Audible Continuity	Audible indication of continuity for low resistance
⎓	Capacitance	Device used to store electrical potential

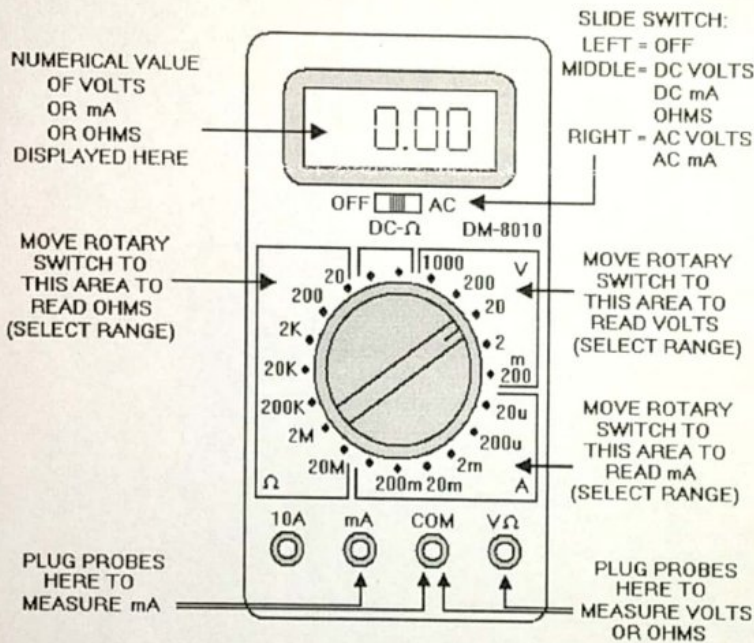

Instrument Input Jacks or Ports The input jacks or ports of a multimeter are the working ends of the instrument. Use care when connecting leads to your instrument. Pay close attention and be sure to connect the leads into the correct port that is marked for the measurement selected on the dial.

DC Voltage Measurements:

To measure DC voltage, we place the Red lead into the **V Ω** and the black lead into **COM** port. Turn the dial or switch to VDC or V. As in the example below, we want to measure the voltage of a 9V battery so the best range would be the 20 V range. Then the voltage displayed is the voltage of the battery

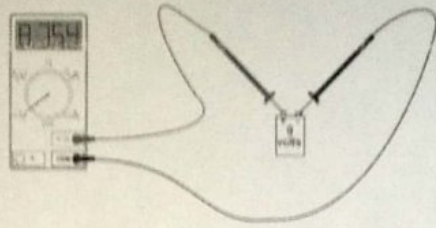

AC Voltage Measurement:

To measure AC voltage, we place the Red lead into the **V Ω** port and black lead into the **COM** port. Turn the dial or switch to **VAC** or **V**. As an example the meter would be set to the **200 V** range to measure a **120V** outlet.

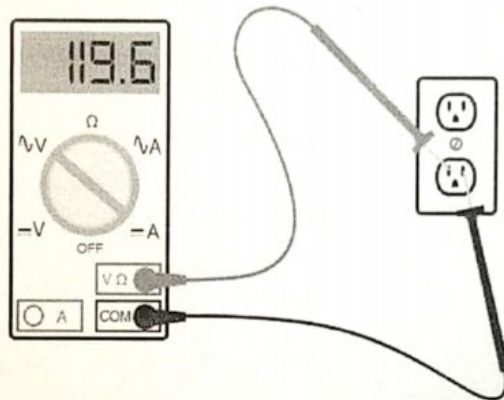

Current Measurements

Current is the electron flow that causes electrical equipment to operate. When the equipment is turned on, it is considered to be a —load on the circuit. A load is any electrical component, such as a lamp, stereo, motor or heating element, that draws current. Current is measured in amperes, or amps. To measure an electric current, red lead is connected to either **mA** or **10A** port and the black lead to **COM** port. The multimeter must be connected in series

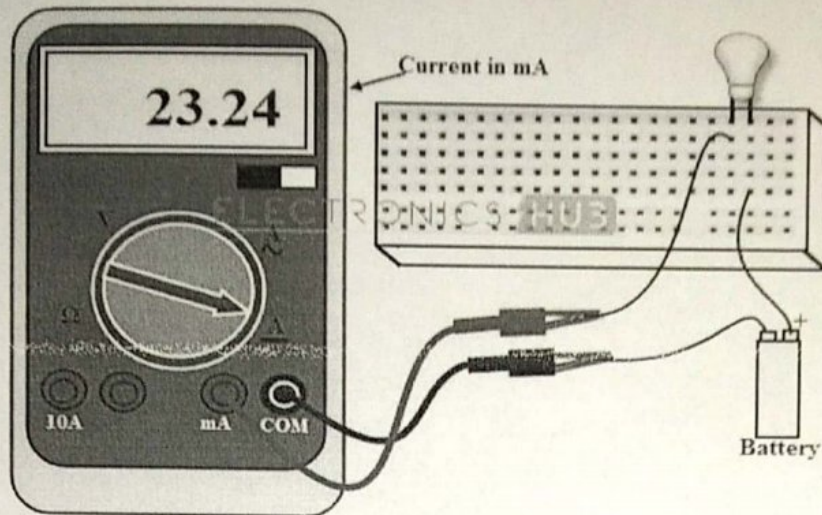

Continuity Measurement

Continuity is a quick check to see if a circuit is complete. Good fuses and closed switches have continuity. During a continuity measurement, the multimeter sends a small current potential through the circuit to measure the resistance of the circuit. The value for the maximum resistance can vary from meter to meter. Most will indicate continuity from 0 to 50 ohms. An audible alarm was added to aid in making fast go-no-go testing without taking your eyes off your work.

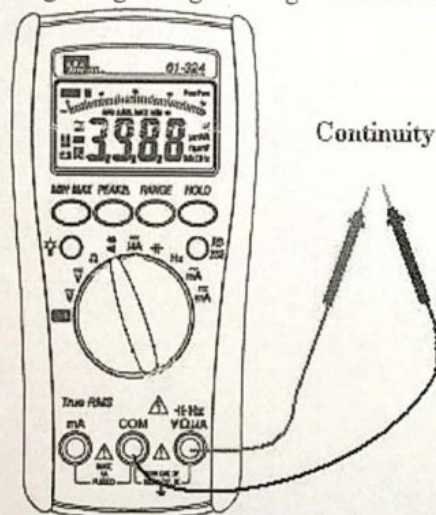

Resistance Measurements

Resistance is measured in Ohms. When you first place the meter in the (Ω) function the meter will give a display of $-OL$ or -1 indicating an infinite reading. It is important when measuring Resistance that the circuit be de-energized or turned off, or the circuit may damage the meter. Most meters have overload protection on all ranges to prevent this, but you should check the specifications of your digital multimeter to be sure.

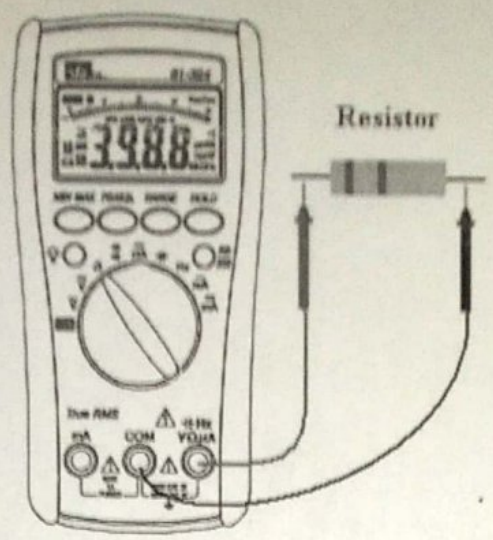

Diode Measurement

A diode is a semiconductor device which allows current to flow in only one direction. The standard Ohms function on a digital multimeter does not supply enough energy to test a diode. The diode function applies an appropriate amount of pressure, (or voltage potential), and measures the voltage drop across the diode.

To test a diode, first measure the forward bias of the diode. For most silicon diodes the voltage drop should measure around .5V +/- .2V.

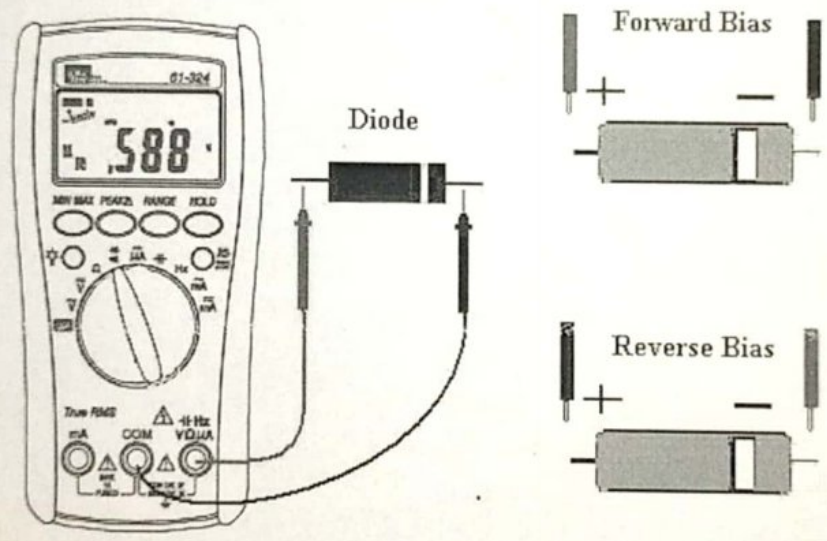

Chapter II: Switches, Potentiometers, Sensors and actuators

Bread board

A breadboard is a circuit board that is used to make temporary circuits. It is a device having electronics and test circuit designs. The electronic elements inside the electronic circuits can be interchanged by inserting the terminals and leads into holes and later connecting it with the help of appropriate wires. The device has stripes of metal below the board that connects the holes placed on the top of the board. The connections of the breadboard are mostly temporary and the elements can further be reassembled and reused without any damage. Breadboards are generally used in electrical engineering. Engineers make use of breadboards in order to test different products made by them. Using breadboard is the most efficient way of testing and also they are cost effective. They can be reused again and again for the purpose of testing.

Breadboards are generally used to test circuits. As this device have holes in it. In order to form a circuit, wires are inserted simply inside the holes. An advantage of using a breadboard is that the positions of the wires can be changed if they are placed in a wrong order. In the below diagram you can see alphabets are used in order to identify vertical columns and numbers are used in order to identify vertical columns.

In the below diagram you can see both the vertical columns and horizontal to be connected internally.

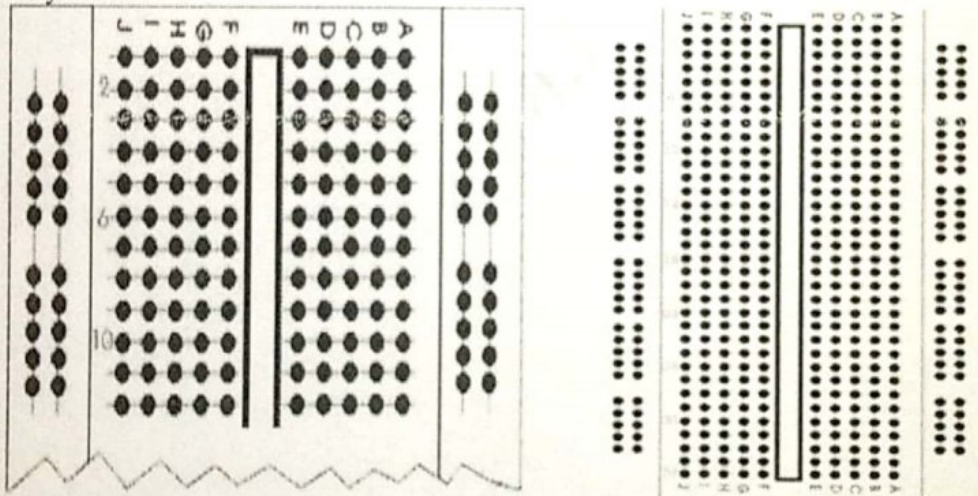

Push button switch

A hand switch / Pushbutton switch is an electrical switch actuated by a person's hand motion. Most pushbutton switches have an internal spring mechanism returning the button to its "out," or "unpressed," position, for momentary operation.

A common form of industrial pushbutton switch looks something like this:

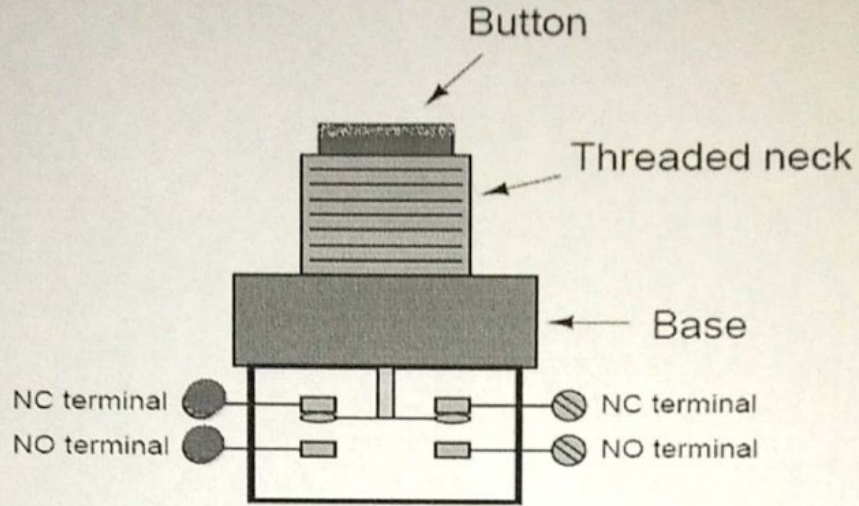

InstrumentationTools.com

When pressed, the downward motion of the actuator breaks the electrical bridge between the two NC contacts, forming a new bridge between the NO contacts:

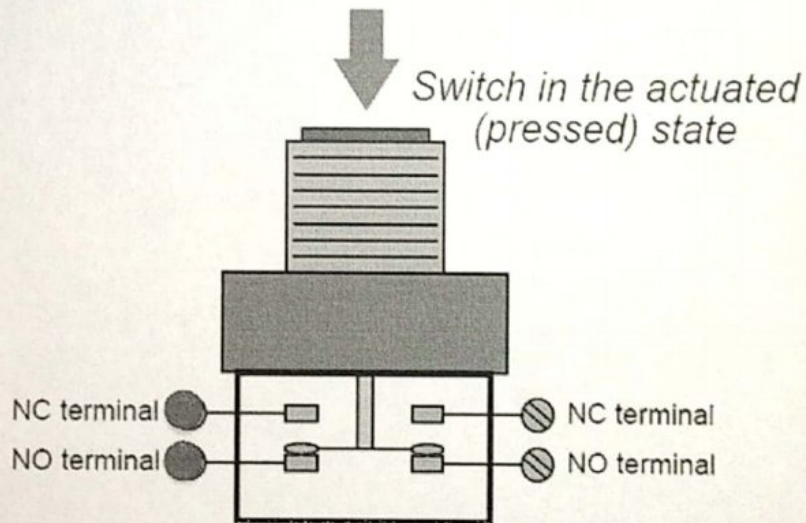

InstrumentationTools.com

The schematic diagram symbol for this type of switch looks much like the real thing, with the normally-closed contact set on top and the normally-open contact set below:

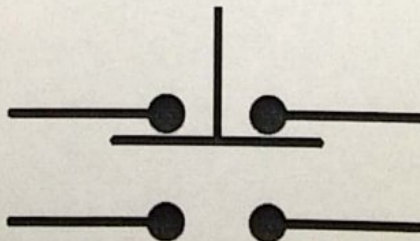

Some pushbutton switches will latch alternately on or off with every push of the button. Other pushbutton switches will stay in their "in," or "pressed," position until the button is pulled back out.

Potentiometers

A potentiometer is a three-terminal resistor where resistance can be manually adjusted to control the current flow. If only two terminals are used, one end and the wiper, it acts as a **variable resistor** or *rheostat*. They are used to accurately measure voltage and help achieve a variable voltage from a fixed-voltage source. Potentiometers are commonly used to control electrical devices such as volume controls on audio equipment, etc.

Construction

Potentiometers comprise a resistive element and a sliding contact (wiper) that moves along the element. Input voltage is applied across the terminals of the resistive element and output voltage is measured at the sliding contact.

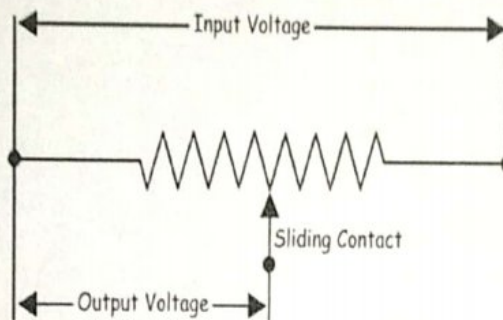

Rotatory potentiometers

These are the most common types of potentiometers where the adjustable wiper moves in an angular (circular) movement using a knob or dial. It is made up of 2 pins connected to a resistive element placed in a semi circular pattern and another connected to a rotary knob.

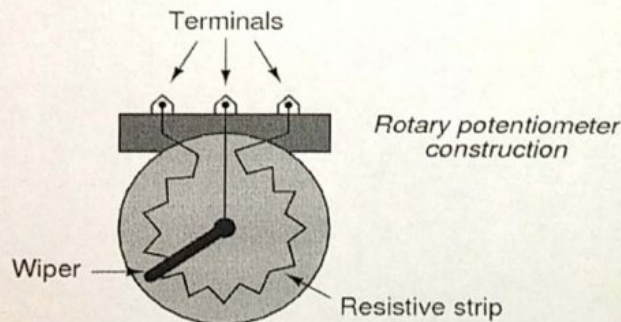

Diode:

A diode is a two terminal electronic device that conducts current in one direction only. It offers low resistance in one direction (forward bias) and high resistance in the other (reverse bias). The schematic symbol for a PN junction diode is shown below. The bar/line on a real diode indicates the cathode terminal and the other terminal would be anode.

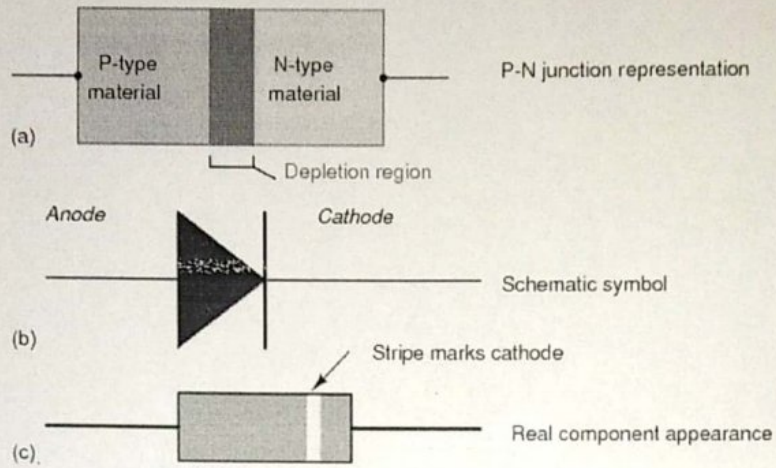

V-I Characteristics of PN junction diode:

The voltage to current characteristic curve of a PN junction diode in forward and reverse bias is shown below. For every PN junction diode, the forward current increases after barrier potential value. It is 0.7 V for germanium based and 1.1 V for silicon based diodes.

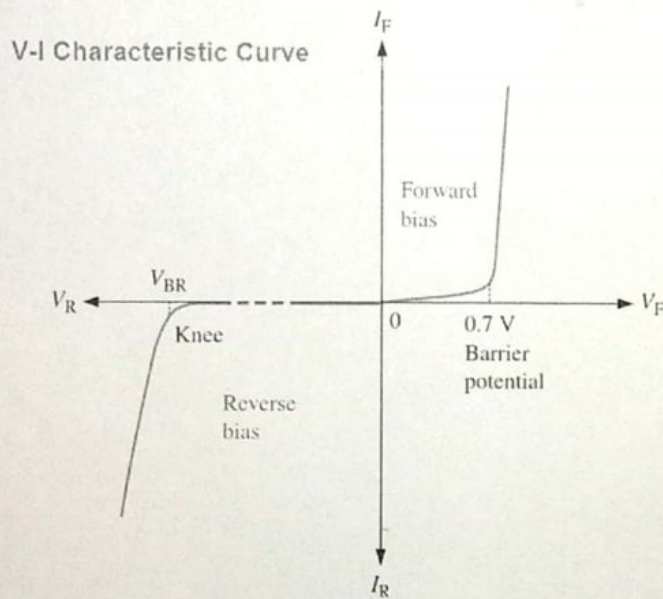

Light Emitting Diode(LED)

A PN Junction diode that emits light under forward bias is known as Light emitting diode. The below diagram shows a schematic and a real life LED. To safe guard an LED, current limiting resistors are used(generally 220/ 330 Ohm). The intensity of light emitted by an LED can be controlled by varying the value of the current limiting resistor. The wavelength / color of light emitted by an LED depends upon the semiconducting material used to design it.

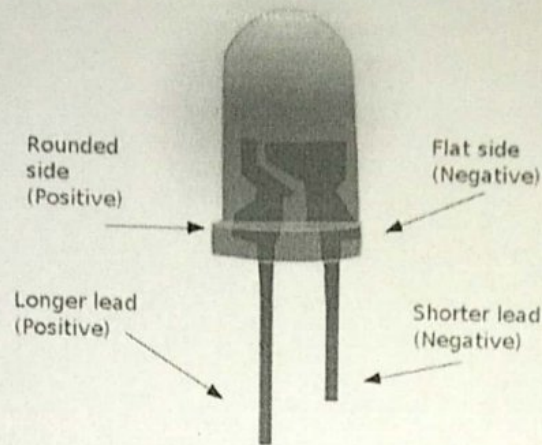

Shorter lead on an LED denotes the cathode and the longer one indicates the anode.

INTRODUCTION TO IOT

IOT (Internet of Things) is a system of devices such as sensors, home appliances, vehicles etc., connected to internet and can be controlled by using a PC or a mobile phone. It is a platform for all the devices to interact and collaborate with each other. Examples of IOT devices are smart bands (activity trackers), Amazon echo, Google home, Nest Cam and Thermostat, Smart TV, Driverless cars etc.,. The unique feature of IOT is that it automatically controls any device connected to the network without human intervention. Thus IOT reduces the human effort and makes things easier.



INTRODUCTION TO ARDUINO

Arduino is an open – source, easy to use electronics platform that includes both hardware and software. The software runs on Mac, Windows and Linux. The Arduino boards can read the data from various sensors and sends signals to actuators.

I) TYPES OF ARDUINO BOARDS

As Arduino design is an open source, several companies and individuals have developed their own Arduino-compatible boards. Anyone is free to make their own Arduino-based derivative, but the name and logo of Arduino are trademarked. Various types of Arduino boards are Arduino UNO, Arduino Leonardo, Arduino Ethernet, Arduino micro (mini), Arduino Due, LilyPad, Arduino Robot, and Arduino Esplora. Each board has different specifications and applications. In this course we are mainly focusing on Arduino UNO.

II) ARDUINO UNO

2. **Analog pins:** These are the six pins starting from A0 to A5. The analog input pins support 10-bit analog-to-digital conversion.

3. **Power pins:** There are 5 power pins on Arduino board. These are Vin, 5V, 3.3 V and two ground pins. Vin is the input voltage to the Arduino board when it's using an external power source.

4. *Other Pins:*

AREF; reference voltage for the analog inputs.

Reset; bring this line LOW to reset the microcontroller.

PROGRAMMING AN ARDUINO:

The software required to program an Arduino is called integrated development Environment (IDE) which can be installed from Arduino's official website. IDE includes a source file editor, a compiler to convert the source file to binary file and a debugger to detect the flaws in the program. The Arduino IDE is a fully integrated piece of software written in Java which can run on multiple platforms. The IDE is available for Windows, Mac OS X, and Linux.

Variables and Data Types:

A variable is a memory location allocated to data(input/output) that can be changed as required. By declaring a variable, you are asking the compiler to allocate a specific amount of memory. When declaring a variable, it is important to first specify the data type and then the variable name. Optionally, you may assign a value by using the equal sign. Finally, finish with a semicolon. An example to declare a variable is shown below.

```
long data;
char usertext;
int pin_number = 42;
```

In the previous example, usertext hints that the variable contains some text that comes from an external source. The variable pin_number = 42; suggests that this is the pin ID for input or output operations

There are different types of data, while writing a sketch we must tell the compiler about the type of data we want to store. Different data types are

Data type	Contents
Void	No data type
Boolean	True or false
Char	One character, stored as an ASCII number ('A', 'B', 'C'...)
unsigned char	Decimal numbers, from 0 to 255
Byte	Decimal numbers, from 0 to 255
Int	Decimal numbers, from -32,768 to 32,767
unsigned int	Decimal numbers, from 0 to 65,535
Word	Decimal numbers, from 0 to 65,535

Long	Decimal numbers, from -2,147,483,648 to 2,147,483,647
unsigned long	Decimal numbers, from 0 to 4,294,967,295
Short	Decimal numbers, -32,768 to 32,767
Float	Floating point numbers, from $-3.4028235 \times 10^{38}$ to 3.4028235×10^{38}
Double	Floating point numbers
String	An array of char
String	Advanced arrays of char
Array	A collection of variables

Conditional statements (if, for, and while):

if Statement

The if statement is the simplest of conditional statements and is used to verify whether an expression is equal to a result. It is used as follows:

```
if (expression)
{
    statement;
}
```

if .. else statement

We can execute two sets of instructions using an if .. else statement. The structure for this is as follows.

```
if (expression)
{
    do_this;
}
Else
{
    do_that;
}
```

while Loop

The while loop will loop over the same code when a condition is satisfied. Consider the following example.

```
while (button == false)
{
    button = check_status(pin4);
}
```

the function check status runs, until it button becomes true. When it happens, the while loop will be broken

I/O Functions

The functions used to access I/O pins are known as I/O functions.

Digital I/O

Digital I/O is defined to communicate using a digital signal generally a logical 1 or logical 0. In Arduino, logic 1 is defined as having a "high" voltage normally 5 or 3.3 volts and logic 0 is defined as having a "low" voltage, which is generally a ground.

pinMode()

In order to use a pin as a digital input/output, we must configure it using pinMode(). It has two parameters pin and Mode. The pin parameter is used to the pin number and mode is used to set the pin to either high or low. For example the statement,

```
pinMode(ledpin output)
```

Sets the ledpin as output pin. Another example is

```
pinMode(2 input)
```

this statement is used to read the voltage at pin 2.

digitalRead()

This function is used to read the state of a digital pin(digital HIGH or digital LOW). For example the function

```
result = digitalRead(2)
```

reads the status of pin 2 and treats it as result.

digitalWrite()

This function is used to write the state of a pin that was already declared as an OUTPUT. digitalWrite(pin, value);

The pin parameter is the pin number you want to write to, and the value is the logical level you want to write; HIGH or LOW.

Arduino IDE

Arduino software is also known as Integrated Development Environment (IDE). It is like a text editor that allows us to write the sketch (code/program) and upload it to Arduino board. One can write the code in two methods, 1) using Online mode and 2) Desktop mode.

Online mode is generally used when we have an active internet connection. All the sketches we write in this mode are saved to Arduino cloud. Desktop mode is used when we are offline. Arduino IDE can be downloaded from Getting Started with Arduino products | Arduino. IDE editor page will be as shown below.

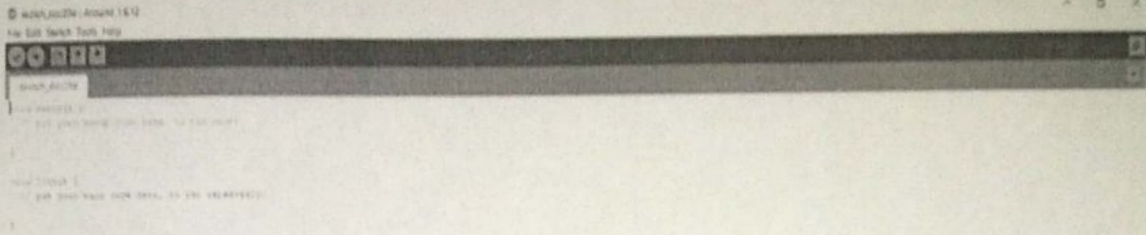

Now we shall work with some of the practical situations of writing sketches using Arduino IDE, compiling and uploading to Arduino UNO board

Project to blink an LED

/*

Blink

Turns an LED on for one second, then off for one second, repeatedly.

Most Arduinos have an on-board LED you can control. On the UNO, MEGA and ZERO it is attached to digital pin 13, on MKR1000 on pin 6. LED_BUILTIN is set to the correct LED pin independent of which board is used.

Schematic

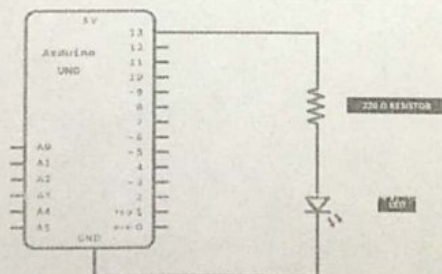

```
// the setup function runs once when you press reset or power the board
void setup() {
  // initialize digital pin LED_BUILTIN as an output.
  pinMode(LED_BUILTIN, OUTPUT);
}

// the loop function runs over and over again forever
void loop() {
  digitalWrite(LED_BUILTIN, HIGH); // turn the LED on (HIGH is the voltage level)
  delay(1000); // wait for a second
  digitalWrite(LED_BUILTIN, LOW); // turn the LED off by making the voltage LOW
  delay(1000); // wait for a second
}
```

Analog read serial

```
/*
  AnalogReadSerial

```

Reads an analog input on pin 0, prints the result to the Serial Monitor.
 Graphical representation is available using Serial Plotter (Tools > Serial Plotter menu).
 Attach the center pin of a potentiometer to pin A0, and the outside pins to +5V and ground.

Schematic

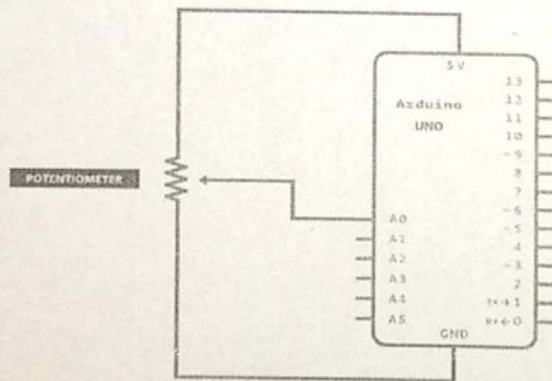

```
// the setup routine runs once when you press reset:
void setup() {
  // initialize serial communication at 9600 bits per second:
  Serial.begin(9600);
}
```

```

// the loop routine runs over and over again forever:
void loop() {
  // read the input on analog pin 0:
  int sensorValue = analogRead(A0);
  // print out the value you read:
  Serial.println(sensorValue);
  delay(1);    // delay in between reads for stability
}

```

Digital read serial

```
/*
```

```
  DigitalReadSerial
```

```
  Reads a digital input on pin 2, prints the result to the Serial Monitor
```

```
  Schematic
```

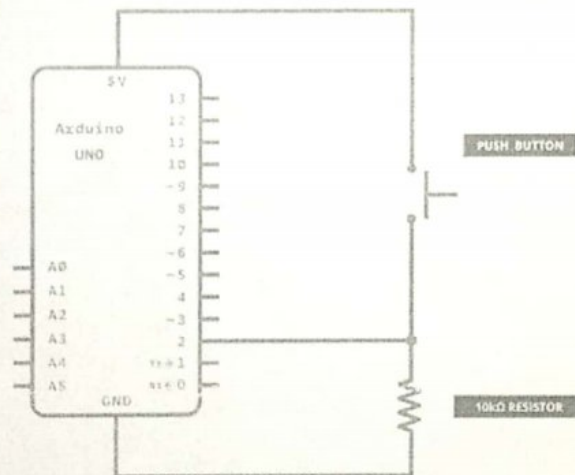

```

// digital pin 2 has a pushbutton attached to it. Give it a name:
int pushButton = 2;

```

```

// the setup routine runs once when you press reset:

```

```

void setup() {
  // initialize serial communication at 9600 bits per second:
  Serial.begin(9600);
  // make the pushbutton's pin an input:
  pinMode(pushButton, INPUT);
}

```

```

// the loop routine runs over and over again forever:
void loop() {
  // read the input pin:
  int buttonState = digitalRead(pushButton);
  // print out the state of the button:
  Serial.println(buttonState);
  delay(1);    // delay in between reads for stability
}

```

Read Analog Voltage

Reads an analog input on pin 0, converts it to voltage, and prints the result to the Serial Monitor.

Graphical representation is available using Serial Plotter (Tools > Serial Plotter menu).

Attach the center pin of a potentiometer to pin A0, and the outside pins to +5V and ground.

*/

Schematic

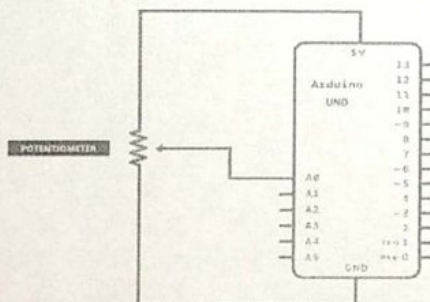

```

// the setup routine runs once when you press reset:
void setup() {
  // initialize serial communication at 9600 bits per second:
  Serial.begin(9600);
}

```

```

// the loop routine runs over and over again forever:

```

```

void loop() {

  // read the input on analog pin 0:

  int sensorValue = analogRead(A0);

  // Convert the analog reading (which goes from 0 - 1023) to a voltage (0 - 5V):

  float voltage = sensorValue * (5.0 / 1023.0);

  // print out the value you read:

  Serial.println(voltage);

}

```

Controlling LED using push button

/*

Button

Turns on and off a light emitting diode(LED) connected to digital pin 13,
when pressing a pushbutton attached to pin 2.

Schematic

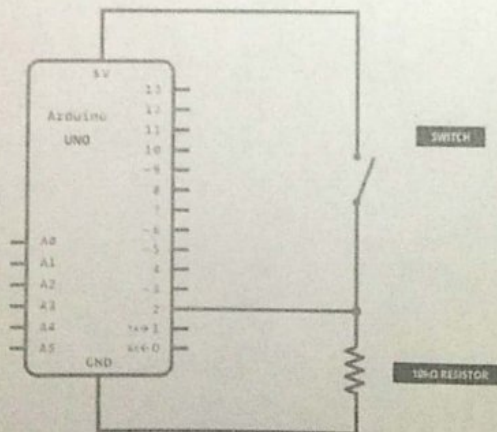

// constants won't change. They're used here to set pin numbers:

```
const int buttonPin = 2; // the number of the pushbutton pin
const int ledPin = 13; // the number of the LED pin

// variables will change:
int buttonState = 0; // variable for reading the pushbutton status

void setup() {
  // initialize the LED pin as an output:
  pinMode(ledPin, OUTPUT);
  // initialize the pushbutton pin as an input:
  pinMode(buttonPin, INPUT);
}

void loop() {
  // read the state of the pushbutton value:
  buttonState = digitalRead(buttonPin);

  // check if the pushbutton is pressed. If it is, the buttonState is HIGH:
  if (buttonState == HIGH) {
    // turn LED on:
    digitalWrite(ledPin, HIGH);
  } else {
    // turn LED off:
    digitalWrite(ledPin, LOW);
  }
}
```

}

Fading

This example demonstrates the use of analog output (Pulse Width Modulation (PWM)) to fade an LED. PWM is a technique for getting an analog-like behavior from a digital output by switching it off and on very fast and with different ratio between on and off time.

Hardware Required

- Arduino board
- LED
- 220 ohm resistor
- hook-up wires
- breadboard

Circuit

An LED connected to digital output pin 9 through a 220 ohm resistor.

Schematic

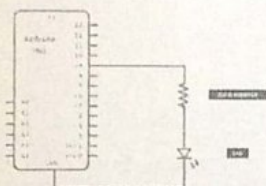

Code

In this example two loops are executed one after the other to increase and then decrease the value of the output on pin 9.

```
/*
```

Fading

This example shows how to fade an LED using the `analogWrite()` function.

The circuit:

- LED attached from digital pin 9 to ground.

```
*/  
  
int ledPin = 9; // LED connected to digital pin 9  
  
void setup() {  
  
    // nothing happens in setup  
}  
  
void loop() {  
  
    // fade in from min to max in increments of 5 points:  
    for (int fadeValue = 0 ; fadeValue <= 255; fadeValue += 5) {  
  
        // sets the value (range from 0 to 255):  
        analogWrite(ledPin, fadeValue);  
  
        // wait for 30 milliseconds to see the dimming effect  
        delay(30);  
  
    }  
  
    // fade out from max to min in increments of 5 points:  
    for (int fadeValue = 255 ; fadeValue >= 0; fadeValue -= 5) {  
  
        // sets the value (range from 0 to 255):  
        analogWrite(ledPin, fadeValue);  
  
        // wait for 30 milliseconds to see the dimming effect  
        delay(30);  
  
    }  
}
```

Led bar graph

Turns on a series of LEDs based on the value of an analog sensor.

This is a simple way to make a bar graph display. Though this graph uses 10 LEDs, you can use any number by changing the LED count and the pins in the array.

This method can be used to control any series of digital outputs that depends on an analog input.

Schematic

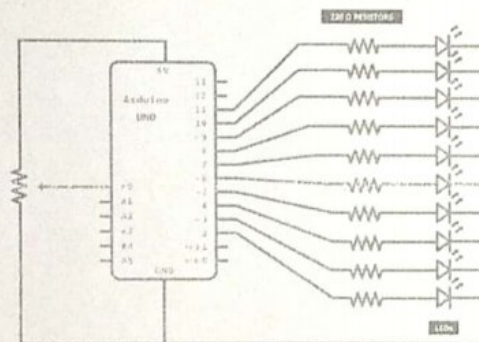

The circuit:

- LEDs from pins 2 through 11 to ground

// these constants won't change:

```
const int analogPin = A0; // the pin that the potentiometer is attached to
```

```
const int ledCount = 10; // the number of LEDs in the bar graph
```

```
int ledPins[] = {
```

```
  2, 3, 4, 5, 6, 7, 8, 9, 10, 11
```

```
}; // an array of pin numbers to which LEDs are attached
```

```
void setup() {  
    // loop over the pin array and set them all to output:  
    for (int thisLed = 0; thisLed < ledCount; thisLed++) {  
        pinMode(ledPins[thisLed], OUTPUT);  
    }  
}  
  
void loop() {  
    // read the potentiometer:  
    int sensorReading = analogRead(analogPin);  
    // map the result to a range from 0 to the number of LEDs:  
    int ledLevel = map(sensorReading, 0, 1023, 0, ledCount);  
  
    // loop over the LED array:  
    for (int thisLed = 0; thisLed < ledCount; thisLed++) {  
        // if the array element's index is less than ledLevel,  
        // turn the pin for this element on:  
        if (thisLed < ledLevel) {  
            digitalWrite(ledPins[thisLed], HIGH);  
        }  
        // turn off all pins higher than the ledLevel:  
        else {  
            digitalWrite(ledPins[thisLed], LOW);  
        }  
    }  
}
```

}
}

Bibliography

1. Types of resistors written in page 2 is taken from <https://www.elprocus.com/different-types-of-resistors-and-color-codes-in-electronic-circuits/>
2. Information about surface mounted resistors(page 6) is obtained from <http://www.resistorguide.com/resistor-smd-code/>
3. <https://cdn-learn.adafruit.com/downloads/pdf/multimeters.pdf>
4. <https://www.idealind.com/content/dam/electrical/assets/TestMeasurement/Multimeters/basics-of-digital-multimeters.pdf>
5. Multimeter dial: <https://electronics.stackexchange.com/questions/446940/what-does-the-multimeter-dial-do-internally>
6. Multimeter symbols and functions: <https://www.pinterest.com/pin/817895982302224822/>
7. Dc and ac voltage measurement: <https://www.allaboutcircuits.com/textbook/direct-current/chpt-3/safe-meter-usage/>
8. Current measurement: <https://www.electronicshub.org/current-measurement-using-multimeter/>
9. Continuity test, diode test: <https://www.sciencebuddies.org/science-fair-projects/references/how-to-use-a-multimeter>
10. Push button switch: <https://instrumentationtools.com/hand-switches/>
11. Diode diagram: [03250.png \(535×313\) \(allaboutcircuits.com\)](#)
12. [instrumentationtools.com_v-i-characteristic-curve-of-diode.png \(783×622\)](#)
13. LED [led_example.png \(500×349\) \(owlcircuits.com\)](#)

COURSE CODE: PHY-C-1-2019-20
SML GOVT.DEGREE COLLEGE, YEMMIGANUR
DEPARTMENT OF PHYSICS
CERTIFICATE COURSE IN ARDUINO PROGRAMMING AND INTERFACING

QUESTION PAPER

TIME: 2 HOURS

MAX. MARKS: 50 M

Answer any FIVE questions

5 x 10 = 50 M

1. State and Explain Ohm's law ? Discuss about the types of resistors.
2. Explain the process to determine the resistance value of a four band resistor. What is the color code of a $10\text{ K}\Omega$ resistor having four bands and a tolerance of 5 % ?
3. Explain the process of continuity test, dc and ac voltage measurement using a digital multimeter ?
4. Explain the V-I characteristics of a PN junction diode. Explain about the working of Light emitting diode.
5. Explain about the block diagram of Arduino micro controller board. Explain about the pin diagram of Arduino UNO.
6. Discuss about I/O functions used to program Arduino UNO. With the help of a schematic, write a sketch to read and display analog voltage using Arduino UNO.

SML Government Degree College Yemmiganur
 Department of Physics
 Certificate course "Arduino Programming and Interfacing"
 ATTENDANCE REGISTER

Regd. No. of student	1	2	3	4	5	6	7	8	9	10	11	12	13	14	15	16	17	18	19	20
18360049001	X	X	X	/	X	X	X	X	X	X	X	X	X	X	X	X	X	X	X	X
18360049002	X	X	X	X	X	X	X	X	X	X	X	X	X	X	X	X	X	X	X	X
18360049004	X	X	X	/	X	X	X	X	X	X	X	X	X	X	X	X	X	X	X	X
18360049006	X	X	X	X	X	X	X	X	X	X	X	X	X	X	X	X	X	X	X	X
18360049010	X	X	X	X	X	X	X	X	X	X	X	X	X	X	X	X	X	X	X	X
18360049012	X	X	X	X	X	X	X	X	X	X	X	X	X	X	X	X	X	X	X	X
18360049016	X	X	X	X	X	X	X	X	X	X	X	X	X	X	X	X	X	X	X	X
18360049017	X	X	X	X	X	X	X	X	X	X	X	X	X	X	X	X	X	X	X	X
18360049018	X	X	X	X	X	X	X	X	X	X	X	X	X	X	X	X	X	X	X	X
18360049019	X	X	X	X	X	X	X	X	X	X	X	X	X	X	X	X	X	X	X	X
18360049020	X	X	X	X	X	X	X	X	X	X	X	X	X	X	X	X	X	X	X	X
18360049021	X	X	X	X	X	X	X	X	X	X	X	X	X	X	X	X	X	X	X	X
19360049004	X	X	X	X	X	X	X	X	X	X	X	X	X	X	X	X	X	X	X	X
19360049005	X	X	X	X	X	X	X	X	X	X	X	X	X	X	X	X	X	X	X	X
19360049007	X	X	X	X	X	X	X	X	X	X	X	X	X	X	X	X	X	X	X	X
19360049008	X	X	X	X	X	X	X	X	X	X	X	X	X	X	X	X	X	X	X	X
19360049010	X	X	X	X	X	X	X	X	X	X	X	X	X	X	X	X	X	X	X	X
19360049012	X	X	X	X	X	X	X	X	X	X	X	X	X	X	X	X	X	X	X	X
19360049013	X	X	X	X	X	X	X	X	X	X	X	X	X	X	X	X	X	X	X	X
19360049021	X	X	X	X	X	X	X	X	X	X	X	X	X	X	X	X	X	X	X	X
19360049023	X	X	X	X	X	X	X	X	X	X	X	X	X	X	X	X	X	X	X	X
19360049014	X	X	X	X	X	X	X	X	X	X	X	X	X	X	X	X	X	X	X	X
173049036	/	X	X	X	X	X	X	X	X	X	X	X	X	X	X	X	X	X	X	X
173049038	X	X	X	X	X	X	X	X	X	X	X	X	X	X	X	X	X	X	X	X
173049039	X	X	X	X	X	X	X	X	X	X	X	X	X	X	X	X	X	X	X	X
173049040	/	X	X	X	X	X	X	X	X	X	X	X	X	X	X	X	X	X	X	X
173049041	X	X	X	X	X	X	X	X	X	X	X	X	X	X	X	X	X	X	X	X
173049042	X	X	X	X	X	X	X	X	X	X	X	X	X	X	X	X	X	X	X	X
173049016	X	X	X	X	X	X	X	X	X	X	X	X	X	X	X	X	X	X	X	X

		1	2	3	4	5	6	7	8	9	10	11	12	13	14	15	16	17	18
30	173049017	X	X	X	X	X	X	X	X	X	X	X	X	X	X	X	X	X	X
31	173049018	X	X	X	X	X	X	X	X	X	X	X	X	X	X	X	X	X	X
32	173049019	X	X	X	X	X	X	X	X	X	X	X	X	X	X	X	X	X	X
33	173049020	X	X	X	X	X	X	X	X	X	X	X	X	X	X	X	X	X	X
34	173049021	X	X	X	X	X	X	X	X	X	X	X	X	X	X	X	X	X	X
35	173049022	X	X	X	X	X	X	X	X	X	X	X	X	X	X	X	X	X	X
36	173049023	X	X	X	X	X	X	X	X	X	X	X	X	X	X	X	X	X	X
37	173049025	X	X	X	X	X	X	X	X	X	X	X	X	X	X	X	X	X	X
38	173049026	X	X	X	X	X	X	X	X	X	X	X	X	X	X	X	X	X	X
39	173049027	X	X	X	X	X	X	X	X	X	X	X	X	X	X	X	X	X	X
40	173049028	X	X	X	X	X	X	X	X	X	X	X	X	X	X	X	X	X	X
41	173049029	X	X	X	X	X	X	X	X	X	X	X	X	X	X	X	X	X	X
42	173049030	X	X	X	X	X	X	X	X	X	X	X	X	X	X	X	X	X	X
43	173049031	X	X	X	X	X	X	X	X	X	X	X	X	X	X	X	X	X	X
44	173049033	X	X	X	X	X	X	X	X	X	X	X	X	X	X	X	X	X	X
45	173049034	X	X	X	X	X	X	X	X	X	X	X	X	X	X	X	X	X	X

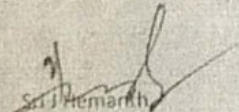
 S. J. Hemarath
 (Convener)

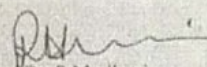

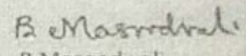
 Dr. R. Madhuri
 (Co-Convener)



 B. Masoodvali
 B Masood vali
 (Coordinator)

SML Government Degree College Yemmiganur
 Department of Physics
 Certificate course "Arduino Programming and Interfacing"
 ATTENDANCE REGISTER

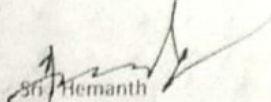
Regd. No. of student	21	22	23	24	25	26	27	28	29	30	31	32	33	34	35	36	37	38	39	40
18360049001	X	X	X	X	X	X	X	X	X	X	X	X	X	X	X	X	X	X	X	X
18360049002	X	X	X	X	X	X	X	X	X	X	X	X	X	X	X	X	X	X	X	X
18360049004	X	X	X	X	X	X	X	X	X	X	X	X	X	X	X	X	X	X	X	X
18360049006	X	X	X	X	X	X	X	X	X	X	X	X	X	X	X	X	X	X	X	X
18360049010	X	X	X	X	X	X	X	X	X	X	X	X	X	X	X	X	X	X	X	X
18360049012	X	X	X	X	X	X	X	X	X	X	X	X	X	X	X	X	X	X	X	X
18360049016	X	X	X	X	X	X	X	X	X	X	X	X	X	X	X	X	X	X	X	X
18360049017	X	X	X	X	X	X	X	X	X	X	X	X	X	X	X	X	X	X	X	X
18360049018	X	X	X	X	X	X	X	X	X	X	X	X	X	X	X	X	X	X	X	X
18360049019	X	X	X	X	X	X	X	X	X	X	X	X	X	X	X	X	X	X	X	X
18360049020	X	X	X	X	X	X	X	X	X	X	X	X	X	X	X	X	X	X	X	X
18360049021	X	X	X	X	X	X	X	X	X	X	X	X	X	X	X	X	X	X	X	X
19360049004	X	X	X	X	X	X	X	X	X	X	X	X	X	X	X	X	X	X	X	X
19360049005	X	X	X	X	X	X	X	X	X	X	X	X	X	X	X	X	X	X	X	X
19360049007	X	X	X	X	X	X	X	X	X	X	X	X	X	X	X	X	X	X	X	X
19360049008	X	X	X	X	X	X	X	X	X	X	X	X	X	X	X	X	X	X	X	X
19360049010	X	X	X	X	X	X	X	X	X	X	X	X	X	X	X	X	X	X	X	X
19360049012	X	X	X	X	X	X	X	X	X	X	X	X	X	X	X	X	X	X	X	X
19360049013	X	X	X	X	X	X	X	X	X	X	X	X	X	X	X	X	X	X	X	X
19360049021	X	X	X	X	X	X	X	X	X	X	X	X	X	X	X	X	X	X	X	X
19360049023	X	X	X	X	X	X	X	X	X	X	X	X	X	X	X	X	X	X	X	X
19360049014	X	X	X	X	X	X	X	X	X	X	X	X	X	X	X	X	X	X	X	X
173049036	X	X	X	X	X	X	X	X	X	X	X	X	X	X	X	X	X	X	X	X
173049038	X	X	X	X	X	X	X	X	X	X	X	X	X	X	X	X	X	X	X	X
173049039	X	X	X	X	X	X	X	X	X	X	X	X	X	X	X	X	X	X	X	X
173049040	X	X	X	X	X	X	X	X	X	X	X	X	X	X	X	X	X	X	X	X
173049041	X	X	X	X	X	X	X	X	X	X	X	X	X	X	X	X	X	X	X	X
173049042	X	X	X	X	X	X	X	X	X	X	X	X	X	X	X	X	X	X	X	X
173049016	X	X	X	X	X	X	X	X	X	X	X	X	X	X	X	X	X	X	X	X

		21	22	23	24	25	26	27	28	29	30	31	32	33	34	35	36	37	38	39	
30	173049017	X	X	X	X	X	X	X	X	X	X	X	X	X	X	X	X	X	X	X	X
31	173049018	X	X	X	X	X	X	X	X	X	X	X	X	X	X	X	X	X	X	X	X
32	173049019	X	X	X	X	X	X	X	X	X	X	X	X	X	X	X	X	X	X	X	X
33	173049020	X	X	X	X	X	X	X	X	X	X	X	X	X	X	X	X	X	X	X	X
34	173049021	X	X	X	X	X	X	X	X	X	X	X	X	X	X	X	X	X	X	X	X
35	173049022	X	X	X	X	X	X	X	X	X	X	X	X	X	X	X	X	X	X	X	X
36	173049023	X	X	X	X	X	X	X	X	X	X	X	X	X	X	X	X	X	X	X	X
37	173049025	X	X	X	X	X	X	X	X	X	X	X	X	X	X	X	X	X	X	X	X
38	173049026	X	X	X	X	X	X	X	X	X	X	X	X	X	X	X	X	X	X	X	X
39	173049027	X	X	X	X	X	X	X	X	X	X	X	X	X	X	X	X	X	X	X	X
40	173049028	X	X	X	X	X	X	X	X	X	X	X	X	X	X	X	X	X	X	X	X
41	173049029	X	X	X	X	X	X	X	X	X	X	X	X	X	X	X	X	X	X	X	X
42	173049030	X	X	X	X	X	X	X	X	X	X	X	X	X	X	X	X	X	X	X	X
43	173049031	X	X	X	X	X	X	X	X	X	X	X	X	X	X	X	X	X	X	X	X
44	173049033	X	X	X	X	X	X	X	X	X	X	X	X	X	X	X	X	X	X	X	X
45	173049034	X	X	X	X	X	X	X	X	X	X	X	X	X	X	X	X	X	X	X	X

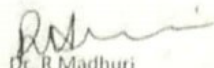
 Sri Hemanth
 (Convener)

 Dr. R Madhuri
 (Co-Convener)

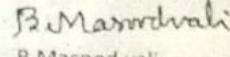

 B. Masood vali
 (Coordinator)

SML Government Degree College Yemmiganur
 Department of Physics
 Certificate course "Arduino Programming and Interfacing"
 ATTENDANCE REGISTER

S. No	Regd. No. of student	11/2	13/2	14/2	15/2	17/2
1	18360049001	X	X	X	X	X
2	18360049002	X	.	.	X	X
3	18360049004	X	X	X	X	X
4	18360049006	X	X	X	X	X
5	18360049010	X	X	X	X	X
6	18360049012	X	X	X	X	X
7	18360049016	X	X	X	X	X
8	18360049017	X	X	X	X	.
9	18360049018	X	X	X	X	X
10	18360049019	X	X	X	X	X
11	18360049020	X	X	X	X	X
12	18360049021	X	X	X	X	X
13	19360049004	X	X	X	X	X
14	19360049005	X	X	X	X	X
15	19360049007	X	X	X	X	X
16	19360049008	X	X	X	X	X
17	19360049010	X	X	X	X	X
18	19360049012	X	X	X	X	X
19	19360049013	X	X	X	X	X
20	19360049021	X	X	X	X	X
21	19360049023	X	X	X	X	X
22	19360049014	X	X	X	X	X
23	173049036	X	X	X	X	X
24	173049038	X	X	X	X	X
25	173049039	X	X	X	X	X
26	173049040	X	X	X	X	X
27	173049041	X	X	X	X	X
28	173049042	X	X	X	X	X
29	173049016	X	X	X	X	X

41 42 43 44 45

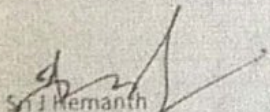
30	173049017	X	X	X	X	X
31	173049018	X	X	X	X	X
32	173049019	X	X	X	X	X
33	173049020	X	X	X	X	X
34	173049021	X	X	X	X	X
35	173049022	X	X	X	X	X
36	173049023	X	X	X	X	X
37	173049025	.	.	.	X	X
38	173049026	X	X	X	X	X
39	173049027	X	X	X	X	X
40	173049028	X	X	X	X	X
41	173049029	X	X	X	X	X
42	173049030	X	X	X	X	X
43	173049031	X	X	X	X	X
44	173049033	X	X	X	X	X
45	173049034	.	.	X	X	X

S. J. Heranth
(Convener)

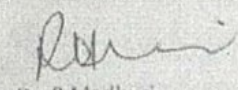
Dr. R. Madhuri
(Co-Convener)

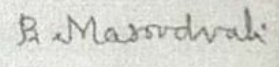
B. Masoodvali
(Coordinator)

COURSE CODE: PHY-C-1-2019-20
SML GOVT DEGREE COLLEGE, YEMMIGANUR

DEPARTMENT OF PHYSICS

CERTIFICATE COURSE IN ARDUINO PROGRAMMING AND INTERFACING

AWARD LIST-2019-20

S.No.	Registered No.	Name of the Student	Theory marks(50)	Practical marks(50)	SUM	GRADE
1	18360049001	B RAMAKRISHNA	38	36	74	B
2	18360049002	B BHEEMA SEKHAR	41	40	81	A
3	18360049004	C NARASIMHULU	37	38	75	A
4	18360049006	G SHIVA RAJU	35	33	68	B
5	18360049010	K SOMI REDDY	39	38	77	A
6	18360049012	M NARASAPPA	36	32	68	B
7	18360049016	S DASTAGIRI	38	36	74	B
8	18360049017	S PRASANNA KUMAR	42	40	82	A
9	18360049018	SHAIK SHA VALI	43	38	81	A
10	18360049019	T BASAVARAJU	36	39	75	A
11	18360049020	T VEERASHEKAR	33	34	67	B
12	18360049021	V DUSHYANTHODU	37	38	75	A
13	19360049004	B THIRUMALESH	33	35	68	B
14	19360049005	C RAMESH	36	38	74	B
15	19360049007	C MAHADEVI	38	42	80	A
16	19360049008	D NAGASRAVANI	35	36	71	B
17	19360049010	D MABASHA	36	37	73	B
18	19360049012	G SANDHYA RANI	39	39	78	A
19	19360049013	K SANA	37	33	70	B
20	19360049021	S SREERAMULU	40	41	81	A
21	19360049023	U LAKSHMINARAYANA	38	35	73	B
22	19360049014	M RAJESWARI	35	36	71	B
23	173049036	B NARASAMMA	33	35	68	B
24	173049038	B VISHNU SWETHA	34	36	70	B
25	173049039	DANDANU VIJAYA KUMAR	36	39	75	A
26	173049040	C SEKHAR	34	36	70	B
27	173049041	PALLE KASIM	35	36	71	B
28	173049042	Y SURYANARAYANA GOUD	36	38	74	B
29	173049016	A SHANKAR	37	40	77	A
30	173049017	B CHINNA RANGANNA	34	36	70	B
31	173049018	BOYA HARI KRISHNA	36	42	78	A
32	173049019	BOYA RANGANNA	34	36	70	B
33	173049020	B T R CHIRANJEEVI	35	38	73	B
34	173049021	C SAIKRISHNA REDDY	34	36	70	B
36	173049023	G AMRUTHA RAJU	24	25	49	C

37	173049025	GUJJALA DAMODHAR	42	39	81	A
38	173049026	K SURYA PRAKASH	40	38	78	A
39	173049027	KADIVELLA GOUSE MODIN	36	37	73	B
40	173049028	KANAKAVEEDU VEERESH	38	35	73	B
41	173049029	KANIKE VEERESH BABU	37	36	73	B
42	173049030	KATHIF YOUNIS BASHA	37	35	72	B
43	173049031	MANGALI SHIREESHA	41	38	79	A
44	173049033	N FAKRUDDIN	23	24	47	C
45	173049034	SHIAK PISARI RASOOL	38	38	76	A

A- Grade >75% , B- Grade >50%, C- Grade <50%

B Masood Vati
B MASOOD VATI

Coordinator

SML Government Degree College, Yerrimiganur

Department of Physics

Feedback of Students about the certificate course "Arduino Programming and Interfacing"

S. No	Regd. No. of student	Name of the student	Group and Class	Feedback
1.	18360049001	B RAMAKRISHNA	B.Sc(M.P.Cs)- II Year	GOOD
2.	18360049002	B BHEEMA SEKIHAR	B.Sc(M.P.Cs)- II Year	Excellent
3.	18360049004	C NARASIMHULU	B.Sc(M.P.Cs)- II Year	Excellent
4.	18360049006	G SHIVA RAJU	B.Sc(M.P.Cs)- II Year	Good
5.	18360049010	K SOMI REDDY	B.Sc(M.P.Cs)- II Year	Excellent
6.	18360049012	M NARASAPPA	B.Sc(M.P.Cs)- II Year	Satisfactory
7.	18360049016	S DASTAGIRI	B.Sc(M.P.Cs)- II Year	EXCELLENT
8.	18360049017	S PRASANNA KUMAR	B.Sc(M.P.Cs)- II Year	Excellent
9.	18360049018	SHAIK SHA VALI	B.Sc(M.P.Cs)- II Year	Excellent
10.	18360049019	T BASAVARAJU	B.Sc(M.P.Cs)- II Year	Good
11.	18360049020	T VEERASHEKAR	B.Sc(M.P.Cs)- II Year	Good
12.	18360049021	V DUSHYANTHODU	B.Sc(M.P.Cs)- II Year	Excellent
13.	19360049004	B THIRUMALES	B.Sc(M.P.Cs)- I Year	Good
14.	19360049005	C RAMESH	B.Sc(M.P.Cs)- I Year	Excellent
15.	19360049007	C MAHADEVI	B.Sc(M.P.Cs)- I Year	Good
16.	19360049008	D NAGASRAVANI	B.Sc(M.P.Cs)- I Year	Excellent
17.	19360049010	D MABASHA	B.Sc(M.P.Cs)- I Year	Satisfactory
18.	19360049012	G SANDHYA RANI	B.Sc(M.P.Cs)- I Year	Excellent
19.	19360049013	K SANA	B.Sc(M.P.Cs)- I Year	Good
20.	19360049021	S SREERAMULU	B.Sc(M.P.Cs)- I Year	Excellent
21.	19360049023	U LAKSHMINARAYANA	B.Sc(M.P.Cs)- I Year	Good
22.	19360049014	M RAJESWARI	B.Sc(M.P.Cs)- I Year	Excellent
23.	173049036	B NARASAMMA	B.Sc(M.P.Cs)- III Year	Good
24.	173049038	B VISHNU SWETHA	B.Sc(M.P.Cs)- III Year	Good
25.	173049039	BANDARU VIJAYA KUMAR	B.Sc(M.P.Cs)- III Year	Excellent
26.	173049040	C SEKIHAR	B.Sc(M.P.Cs)- III Year	Good
27.	173049041	PALLE KASIM	B.Sc(M.P.Cs)- III Year	Satisfactory
28.	173049042	Y SURYANARAYANA GOUD	B.Sc(M.P.Cs)- III Year	Good
29.	173049016	A SHANKAR	B.Sc(M.P.Cs)- III Year	Excellent
30.	173049017	BOYA CHINNA RANGANNA	B.Sc(M.P.Cs)- III Year	Satisfactory
31.	173049018	BOYA HARI KRISHNA	B.Sc(M.P.Cs)- III Year	GOOD
32.	173049019	BOYA RANGANNA	B.Sc(M.P.Cs)- III Year	Good
33.	173049020	B T R CHIRANJEVI	B.Sc(M.P.Cs)- III Year	Satisfactory
34.	173049021	C SAIKRISHNA REDDY	B.Sc(M.P.Cs)- III Year	Excellent
35.	173049022	CHIKKEM VIJAY KUMAR	B.Sc(M.P.Cs)- III Year	Excellent

S. No	Regd. No. of student	Name of the student	Group and Class	Feedback
36.	173049023	GANDALAM AMRUTHA RAJU	B.Sc(M.P.Cs)- III Year	Excellent
37.	173049025	GUJJALA DAMODHAR	B.Sc(M.P.Cs)- III Year	Excellent
38.	173049026	K SURYA PRAKASH	B.Sc(M.P.Cs)- III Year	Good
39.	173049027	KADIVELLA GOUSE MODIN	B.Sc(M.P.Cs)- III Year	Satisfactory
40.	173049028	KANAKAVEEDU VEERESH	B.Sc(M.P.Cs)- III Year	Good
41.	173049029	KANIKE VEERESH BABU	B.Sc(M.P.Cs)- III Year	Excellent
42.	173049030	KATHIF YOUNIS BASHA	B.Sc(M.P.Cs)- III Year	Good
43.	173049031	MANGALI SHIREESHA	B.Sc(M.P.Cs)- III Year	Excellent
44.	173049033	NANDAVARAM FAKRUDDIN	B.Sc(M.P.Cs)- III Year	Good
45.	173049034	SHIAK PISARI RASOOL	B.Sc(M.P.Cs)- III Year	Excellent

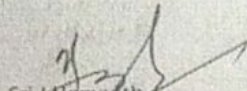
Sri Hemanth
(Convener)

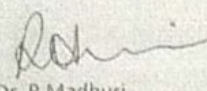
Dr. R Madhuri
(Co- Convener)

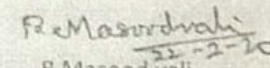
B Masood vali
(Coordinator)

Certificate of Appreciation

This is to certify that Mr./Miss D NAGASRAVANI of II MPC/MPCs with Registration No. 19360049008 has completed a short term certificate course in *Arduino programming and Interfacing* organised by the Department of Physics, S.M.L Government Degree College, Yemmiganur Kurnool(Dt.) during the academic year 2019-2020, from 17-12-2019 to 22-02-2020.

B Masoodvali
COORDINATOR
Sri. B MASOOD VALI

Sri. J HEMANTH

Dr. K MAHABOOB BASHA

Certificate of Appreciation

This is to certify that Mr./Miss M RATESWARI of II MPC/MPCs with Registration No. 19360049014 has completed a short term certificate course in *Arduino programming and Interfacing* organised by the Department of Physics, S.M.L Government Degree College, Yemmiganur Kurnool(Dt.) during the academic year 2019-2020, from 17-12-2019 to 22-02-2020.

B Masoodvali
COORDINATOR
Sri. B MASOOD VALI

Sri. J HEMANTH

Dr. K MAHABOOB BASHA

Certificate of Appreciation

This is to certify that Mr./Miss S SREE RAMULU of II MPC/MPCs with Registration No. 19360049021 has completed a short term certificate course in *Arduino programming and Interfacing* organised by the Department of Physics, S.M.L Government Degree College, Yemmiganur Kurnool(Dt.) during the academic year 2019-2020, from 17-12-2019 to 22-02-2020.

B Masood Vali
Sri. B MASOOD VALI

J Hemanth
Sri. J HEMANTH

K Mahabob Basha
Dr. K MAHABOOB BASHA

THANK YOU

ORGANISED BY
THE DEPARTMENT OF PHYSICS, 2019-2020.

Sri J Hemanth
(Convener)

Dr. R Madhuri
(Co- Convener)

B Masood vali
(Coordinator)

SMLOED

p



